



US006394833B1

(12) **United States Patent**
Bulmer et al.

(10) **Patent No.:** **US 6,394,833 B1**
(45) **Date of Patent:** **May 28, 2002**

(54) **FLAT FLEXIBLE CABLE CONNECTOR**

(75) Inventors: **Douglas R. Bulmer**, Windham; **Joseph A. Roberts, II**, Hudson, both of NH (US)

(73) Assignee: **Miraco, Inc.**, Manchester, NH (US)

(*) Notice: Subject to any disclaimer, the term of this patent is extended or adjusted under 35 U.S.C. 154(b) by 0 days.

(21) Appl. No.: **09/843,317**

(22) Filed: **Apr. 25, 2001**

(51) **Int. Cl.⁷** **H01R 4/24**

(52) **U.S. Cl.** **439/393; 439/496**

(58) **Field of Search** 439/393, 496,
439/404, 406, 400, 405, 397, 417

(56) **References Cited**

U.S. PATENT DOCUMENTS

3,333,229 A	*	7/1967	Dean et al.	439/417
4,573,752 A	*	3/1986	Rich	439/77
5,069,625 A	*	12/1991	Brandt	439/404
6,193,541 B1	*	2/2001	Lee	439/405

* cited by examiner

Primary Examiner—Tulsidas Patel

(74) *Attorney, Agent, or Firm*—Devine, Millimet & Branch, P.A.; Paul C. Remus; Todd A. Sullivan

(57) **ABSTRACT**

This invention results from the realization that a multiple conductor cable connector can be made more compact than previously available connectors by using a more narrow contact for each conductor in the cable, can be made more convenient by enabling all conductors contained in the cable to be connected with a single user motion, and can connect to cable without damaging the mechanical or electrical integrity of the cable conductors. This invention is an electrical connector for connecting multiple conductor cable, ideally flat flexible cable. The inventive electrical connector has a base for holding multiple contacts. The contacts should be positioned substantially in parallel with each other and are located at least partially within the base of the electrical connector. Each contact has at least one cutting edge. The cutting edge is preferably a part of the contact with a sharp edge capable of removing insulation from flat flexible cable. The final part of the electrical connector, in its broadest form, is an actuator, interlockable with the base, for pressing the multiple conductor cable against the multiple contacts.

25 Claims, 16 Drawing Sheets

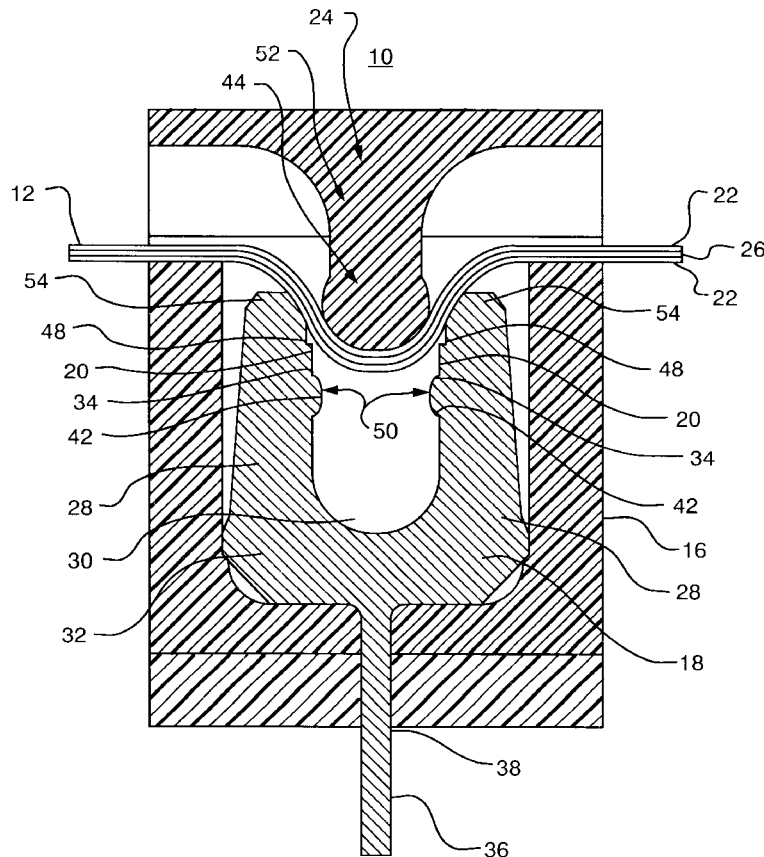

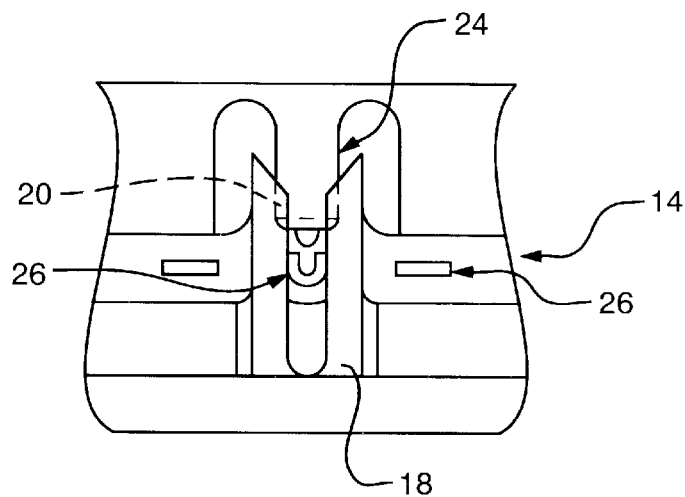

FIG. 1
(PRIOR ART)

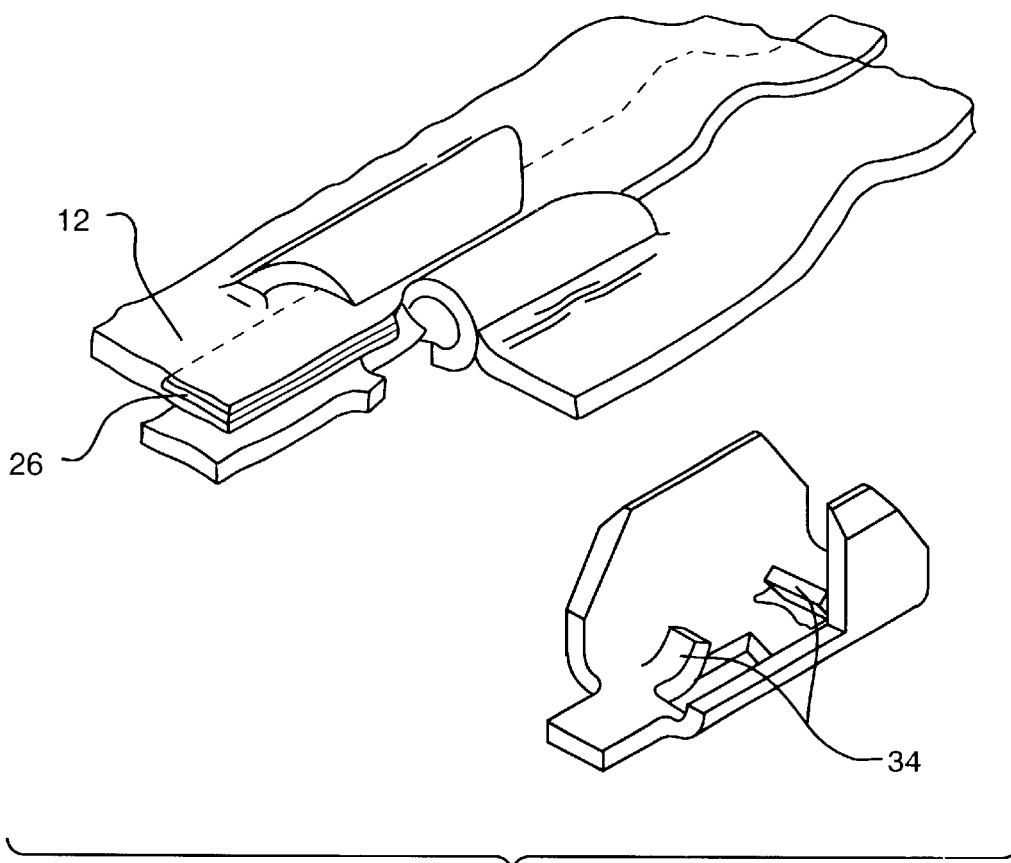

FIG. 2
(PRIOR ART)

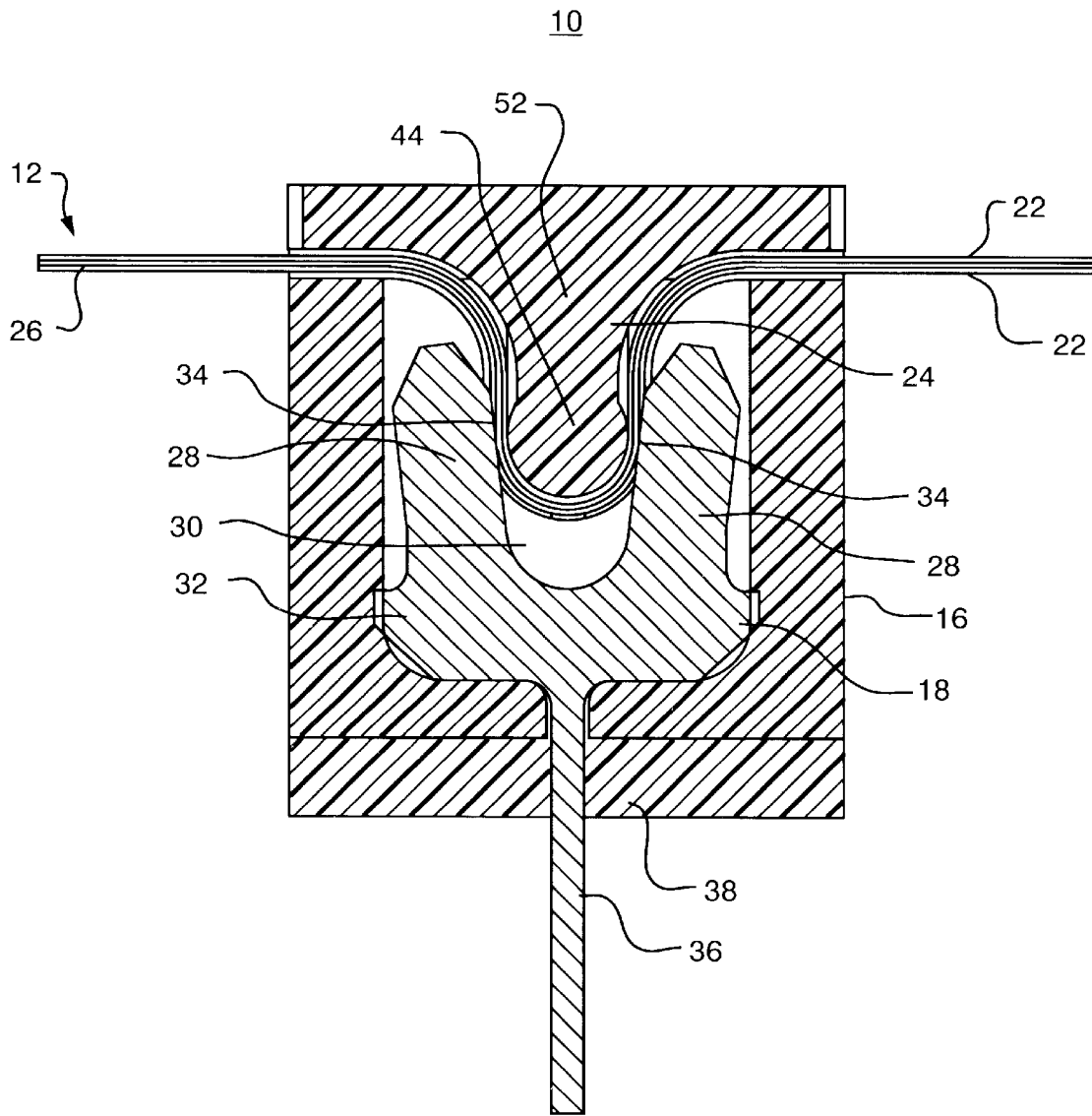

FIG. 3

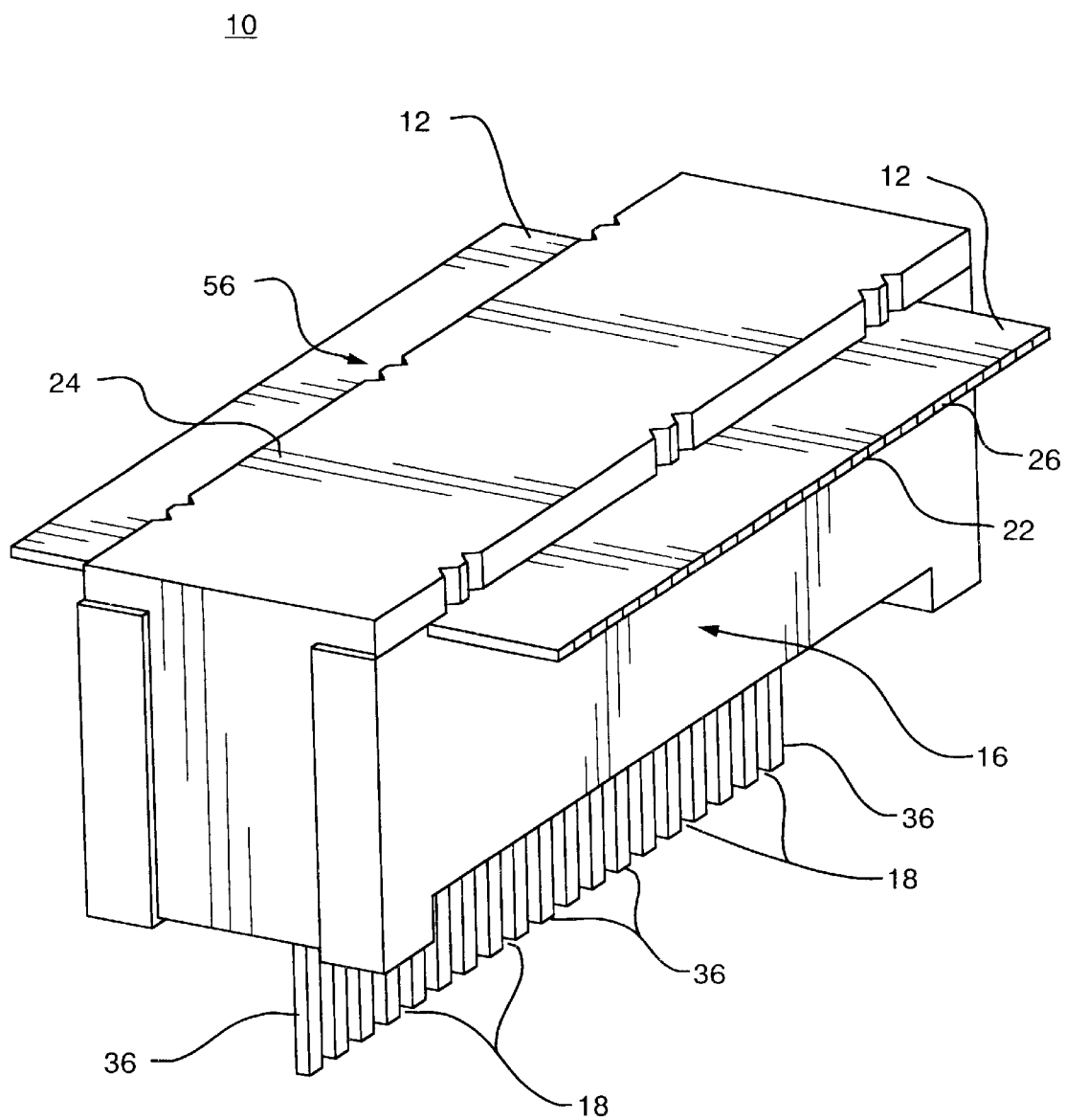

FIG. 4

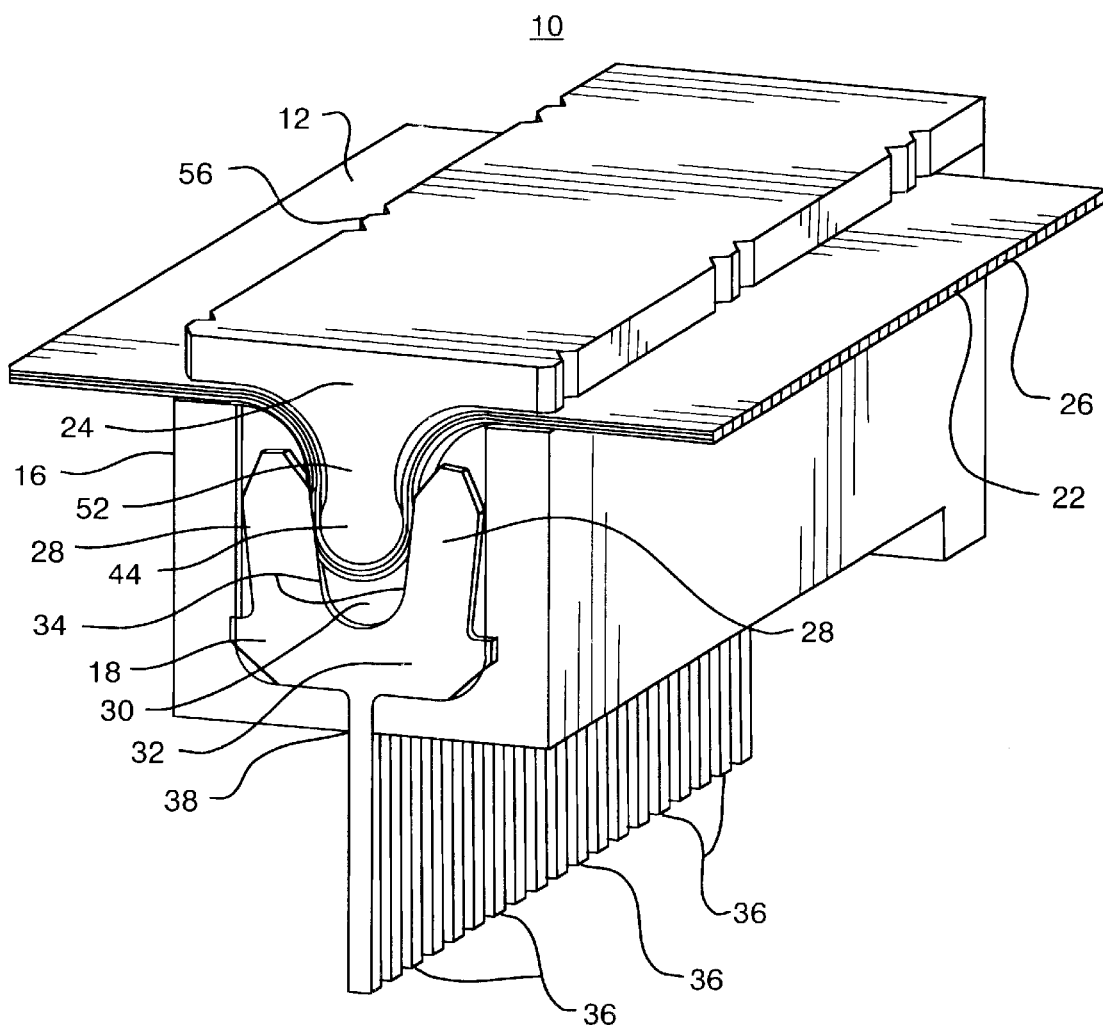

FIG. 5

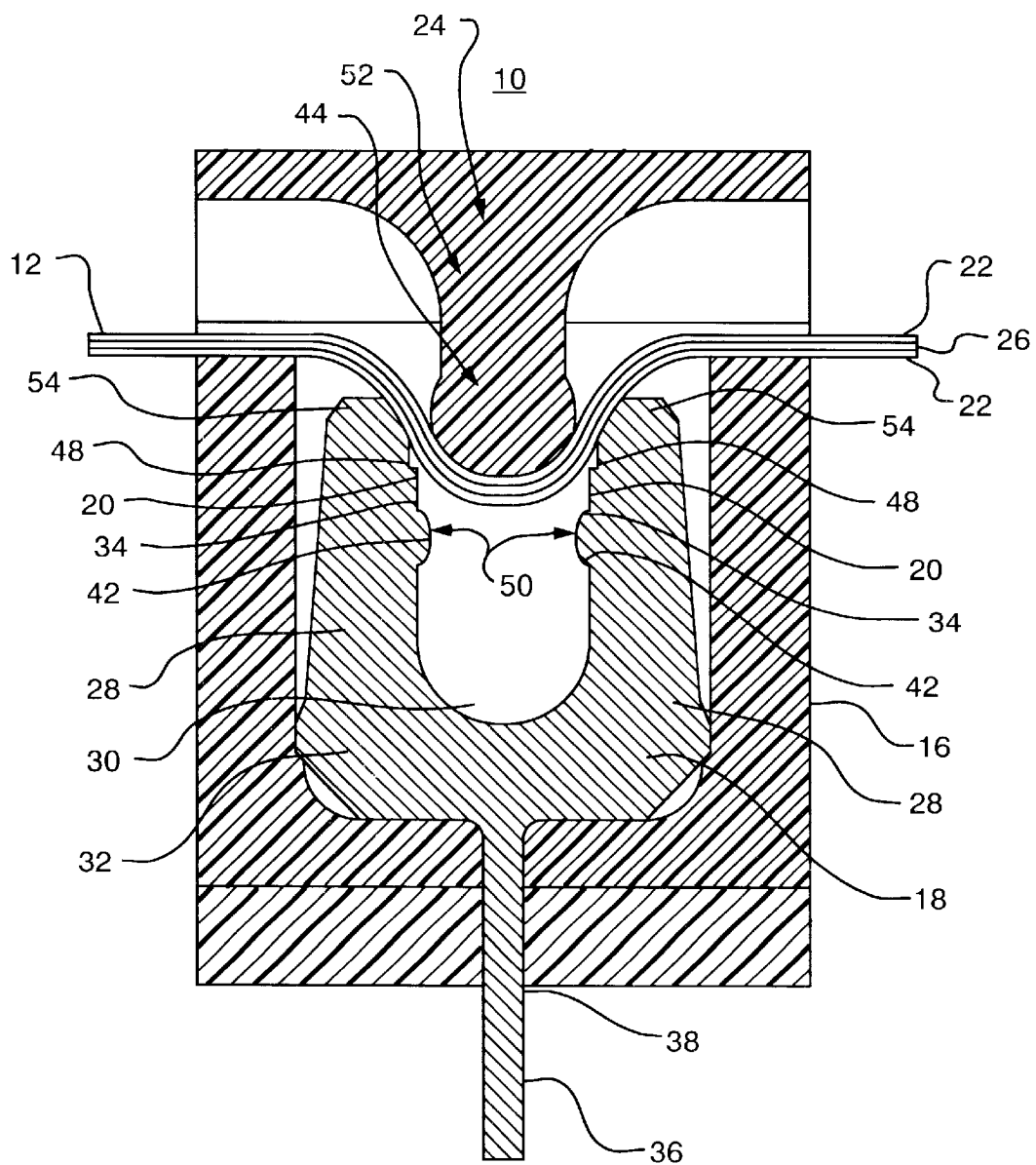

FIG. 6

16

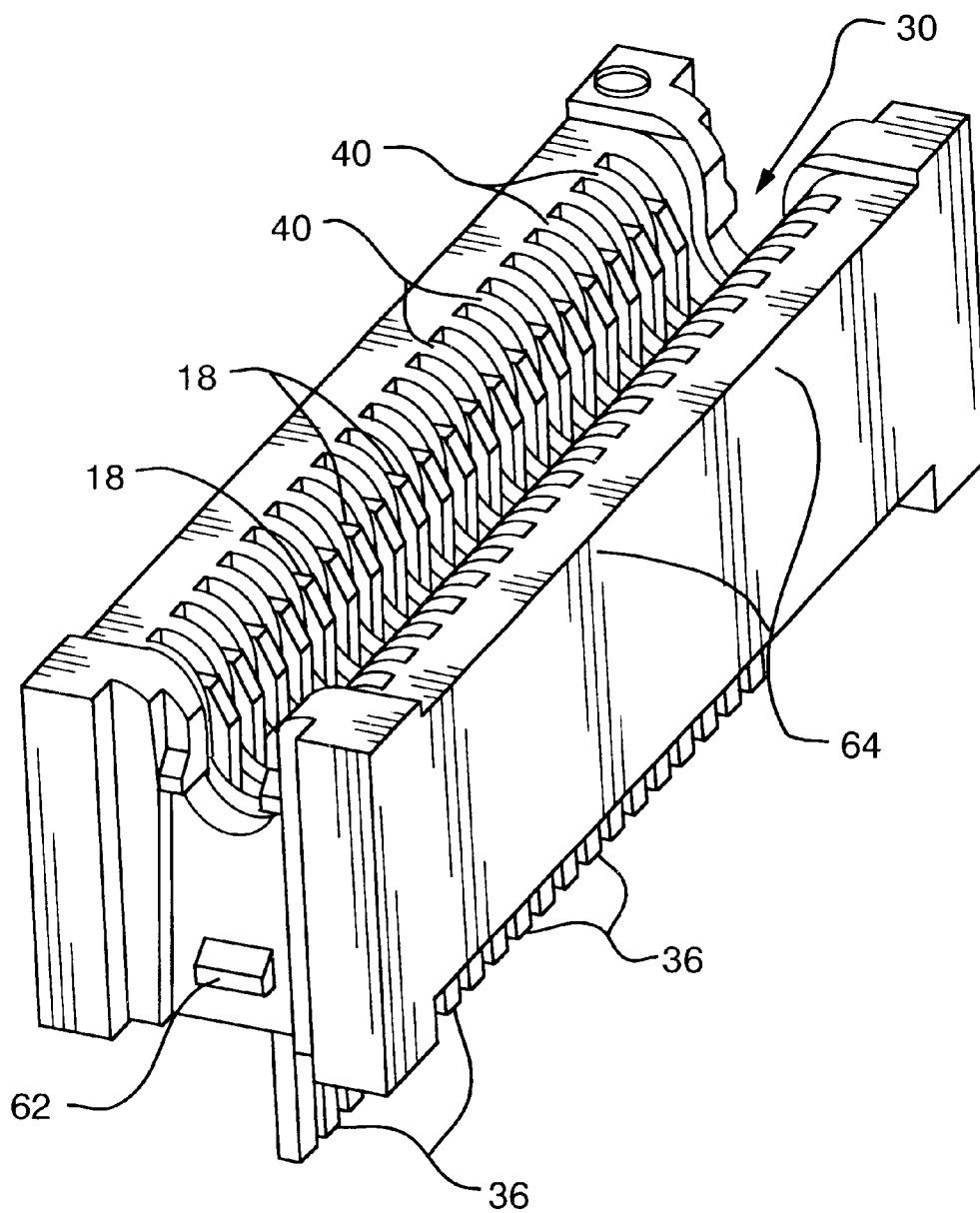

FIG. 7

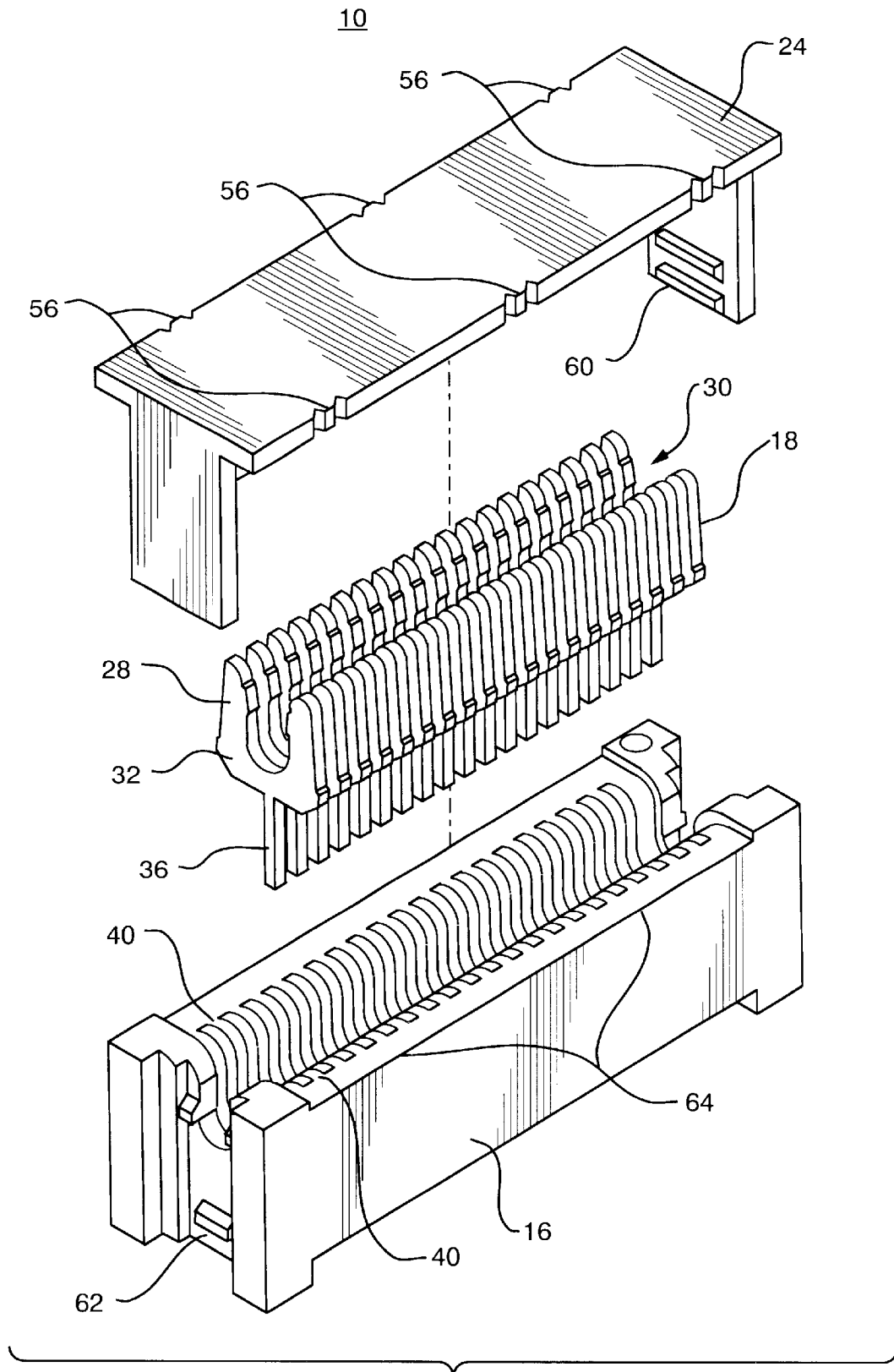

FIG. 8

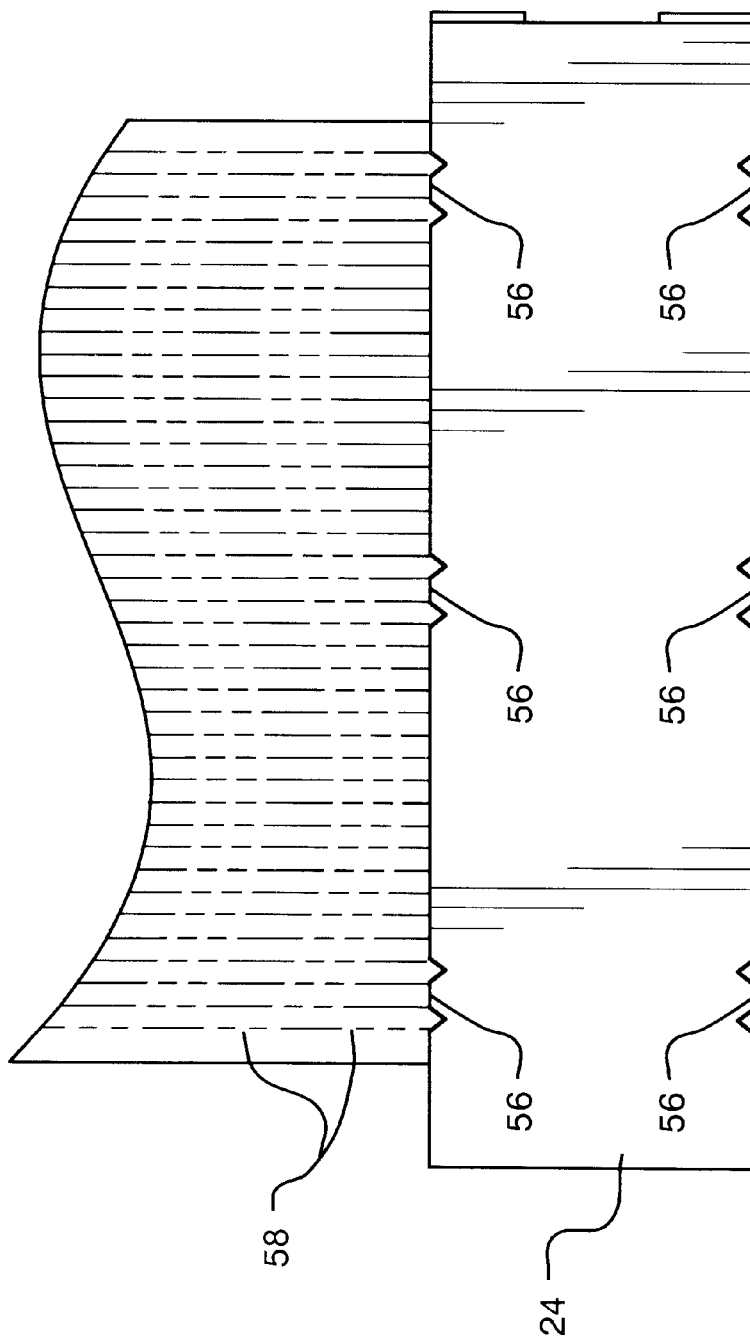

FIG. 9

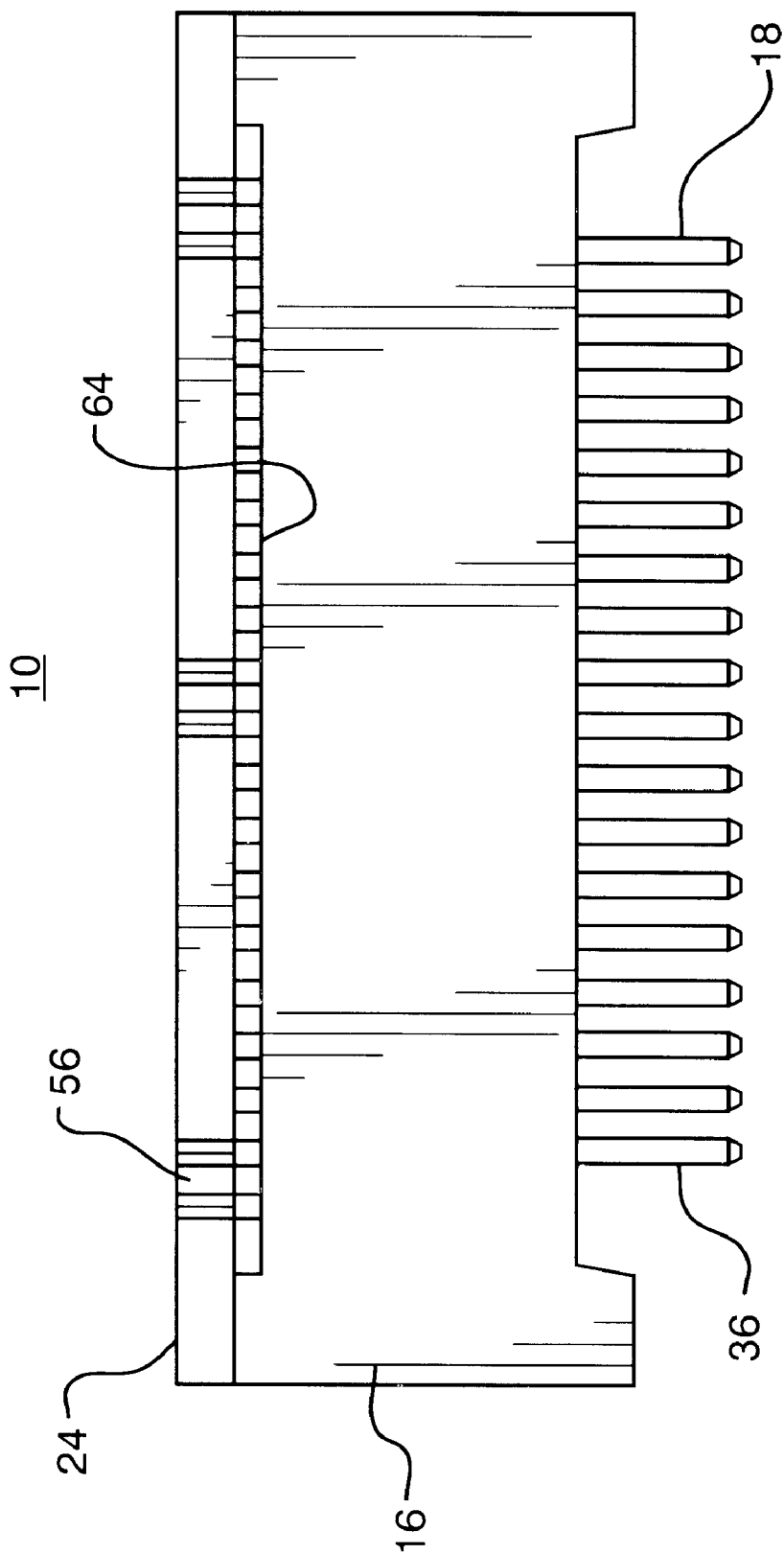

FIG. 10

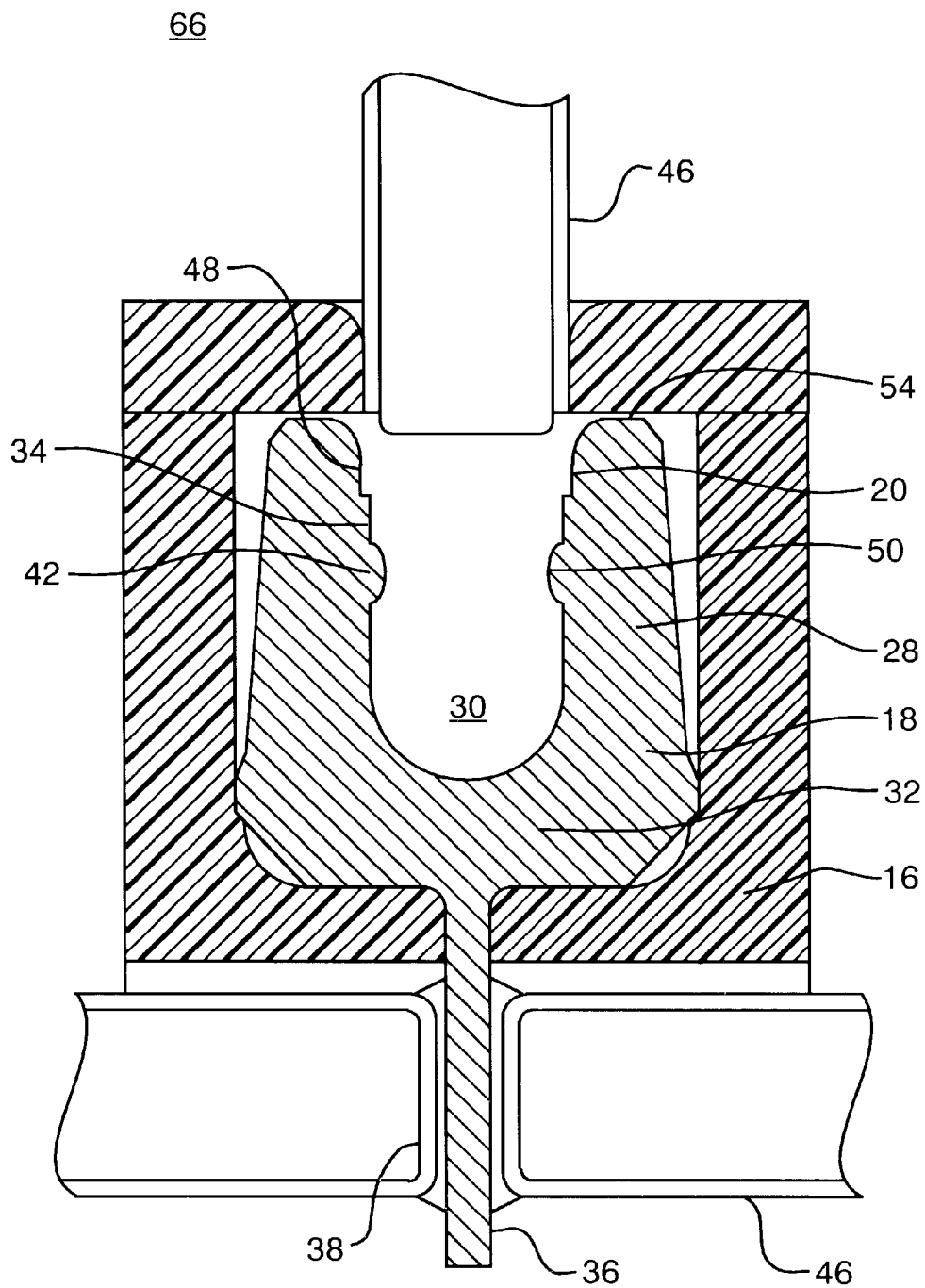

FIG. 11

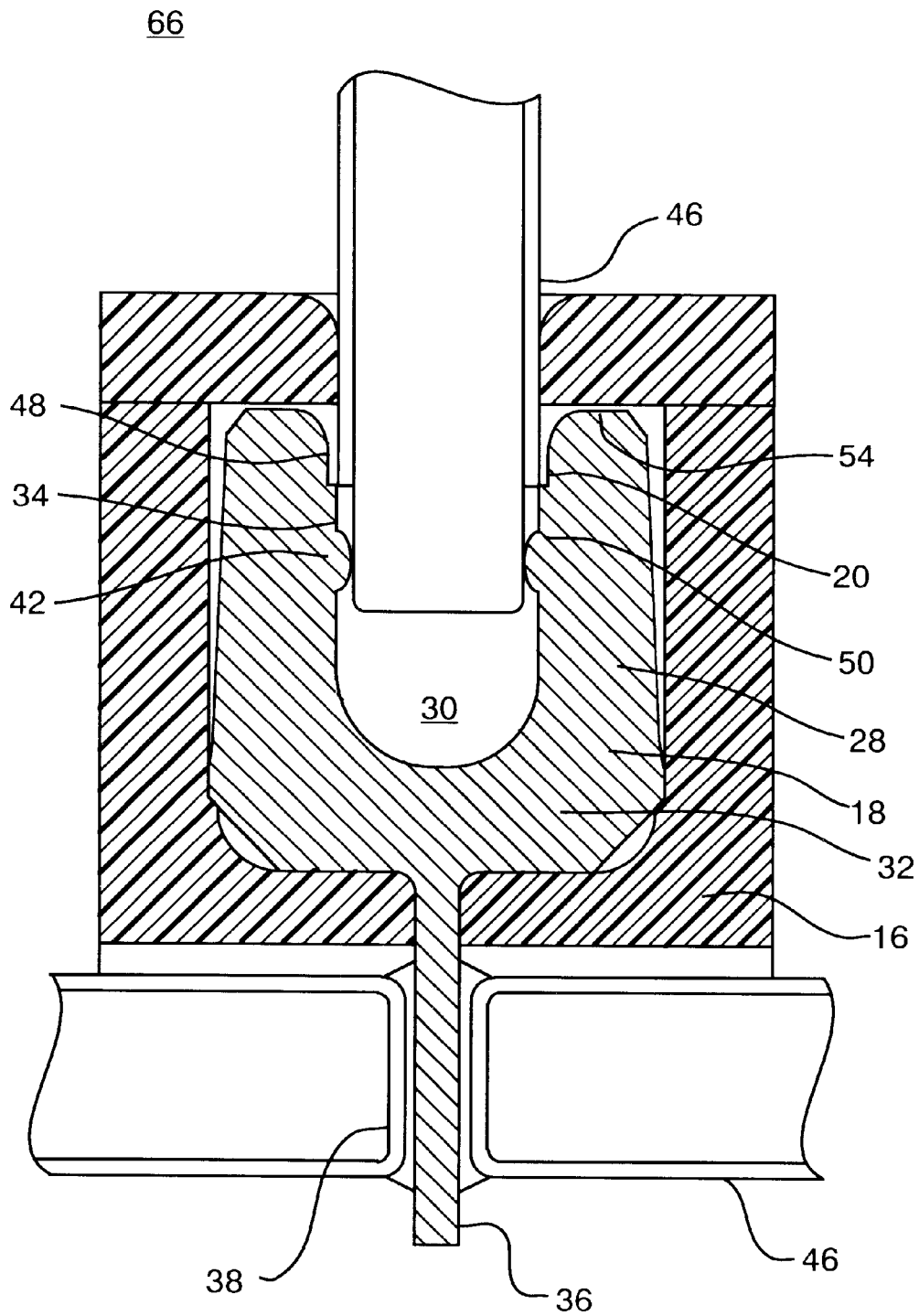

FIG. 12

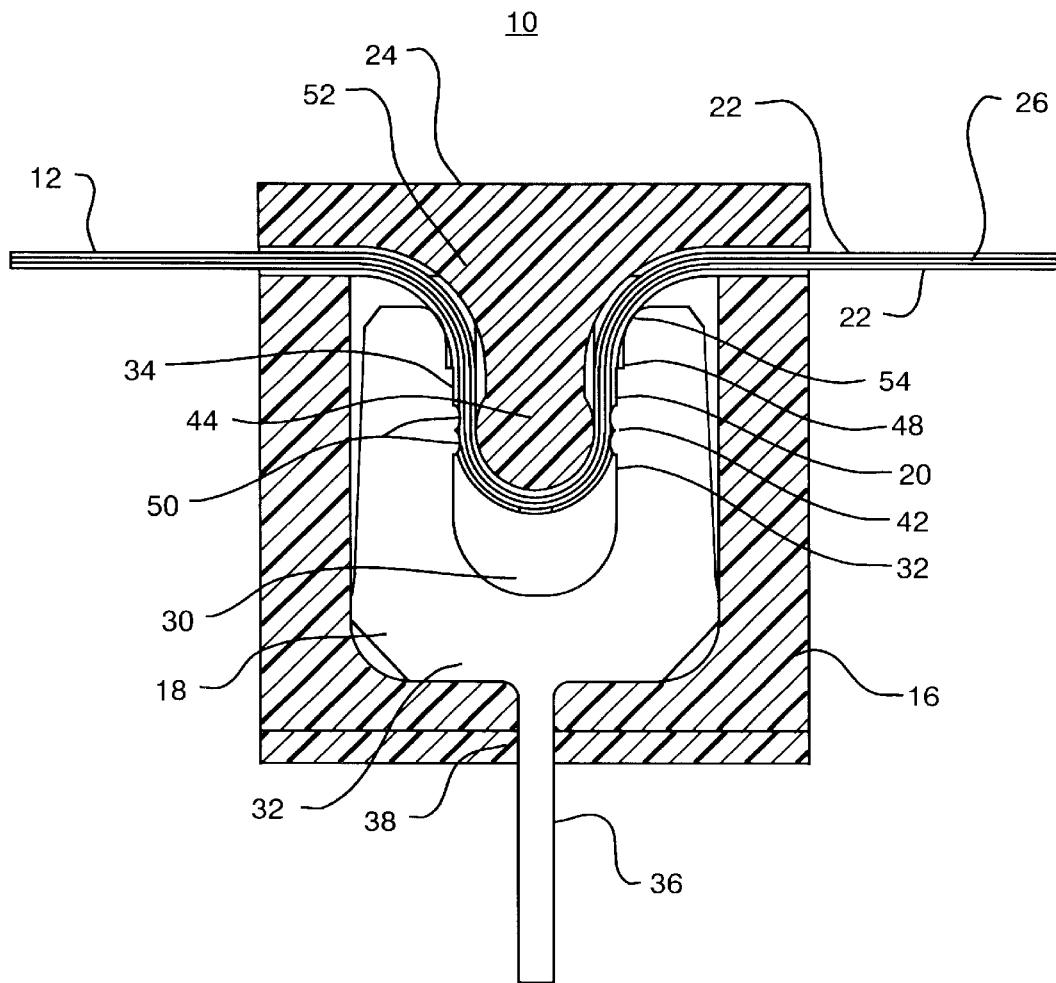

FIG. 13

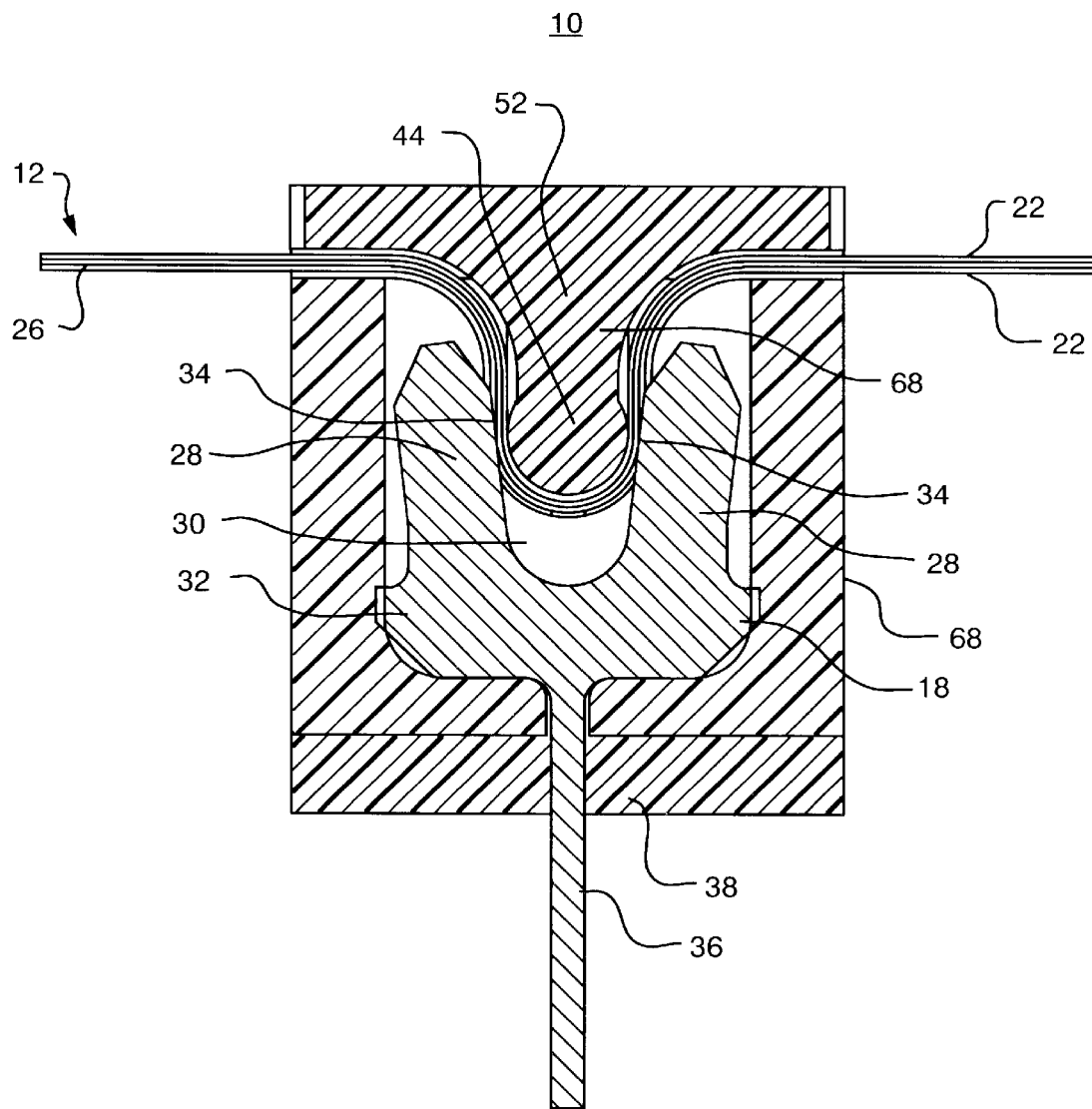

FIG. 15

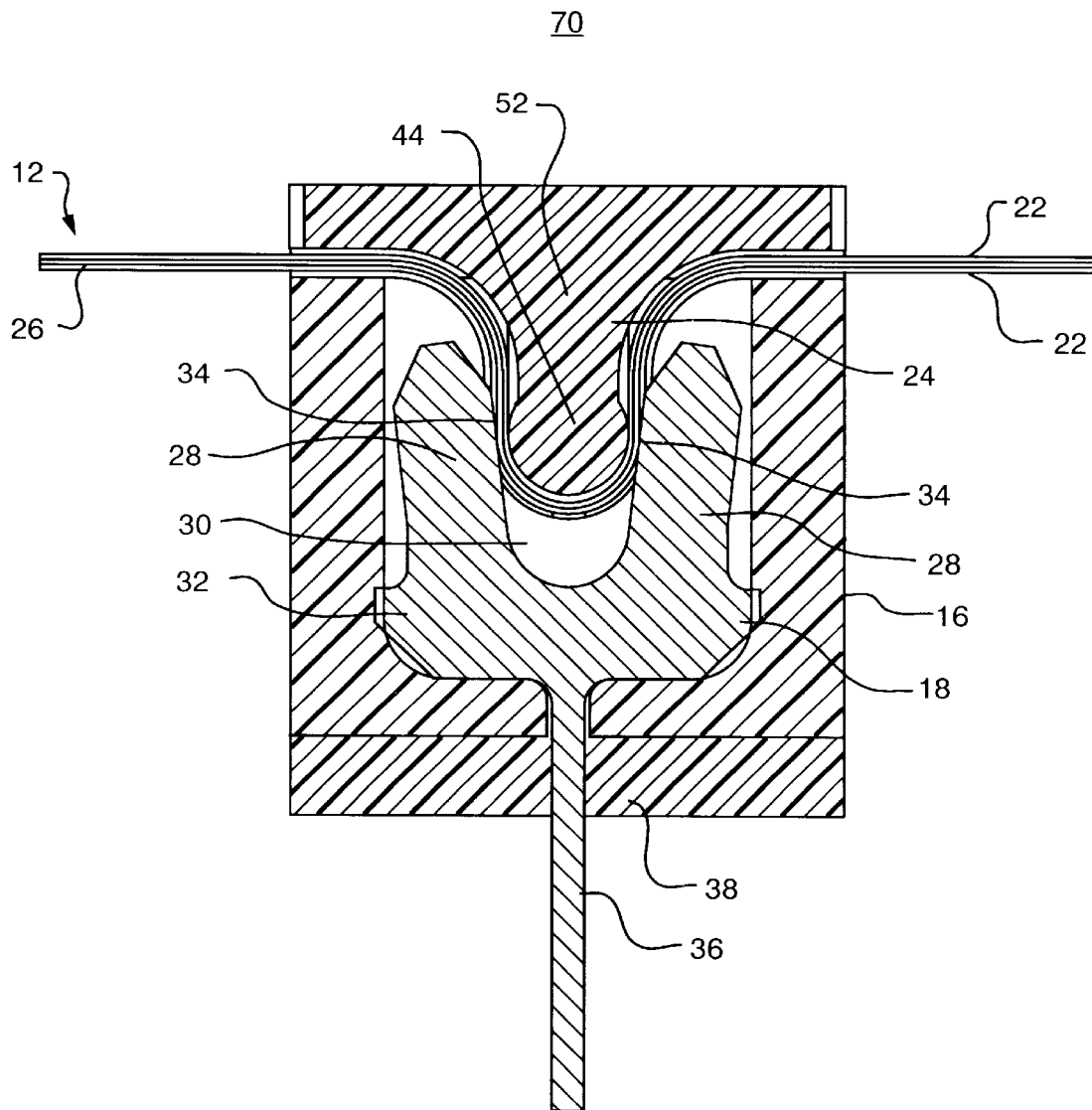

FIG. 16

12

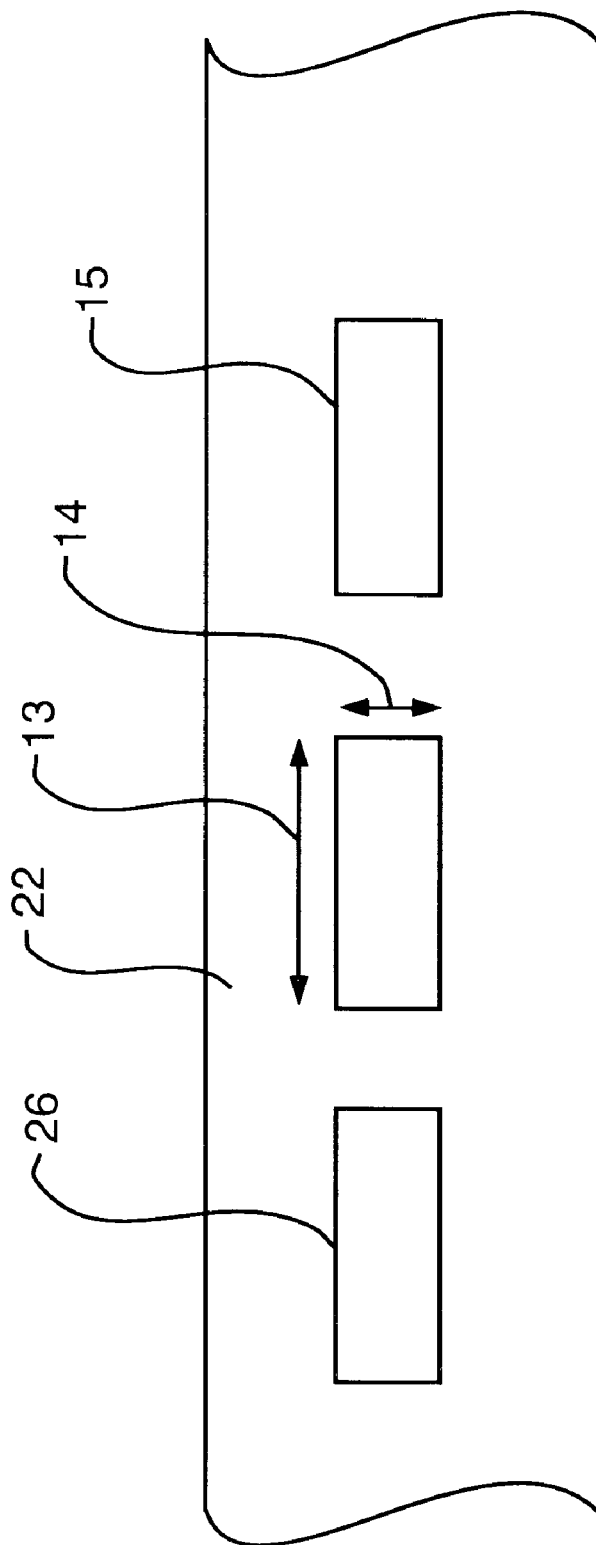

FIG. 17

FLAT FLEXIBLE CABLE CONNECTOR**FIELD OF THE INVENTION**

This invention relates to the field of electrical connectors. Specifically, this invention relates to the field of electrical connectors for multi-conductor cable.

BACKGROUND OF THE INVENTION

The present invention is an Insulation Displacement Connector (IDC) for use with multi-conductor cable, such as Flat Flexible Cable (FFC) and Flexible Printed Circuits (FPC) which would provide the same convenience, cost savings, and long-term reliability that has been available for solid conductor round wire connections using the "U" form contact for over two decades. The result is a design that successfully translates IDC technology used for round wire interconnects to flat conductor systems.

The "U" form IDC contact was originally developed for the telephone industry to terminate solid and stranded core, round conductor wire. In these connectors, "U" shaped metal contacts are used to both pierce through and displace the insulation to make a gas-tight contact with the underlying conductor(s) of either a single conductor round wire or multi-conductor laminated round wire cable.

Application of an IDC for use with multi-conductor cable can result in a significant cost savings. With current connectors, the conductors of the multi-conductor cable must be exposed in the area that the interconnection will be made. Some connectors require exposure on both sides and others require either the addition of a stiffening film to the backside of the cable in the connector area or holes punched in the cable for positioning and strain relieving. The end user must specify and purchase the multi-conductor cable at specific lengths with the exposed areas either punched or laser cut and the holes either punched or drilled. Each of these operations has a cost and tolerances associated with it. Failure to meet the tolerances will result in rejected product, lost time, and lost money. With an IDC, exposing the conductors before assembly is not required and an assembler can simply use continuous lengths of multi-conductor cable that can be cut to length without any special tooling.

Until now, there have been few applications for this technology for flat conductor cables. Previous IDC connector designs have attempted to translate the technology used for round wire to flat conductor cable but have included severe limitations. FIG. 1 shows an example of an IDC connector attempting to use round wire technology for flat conductor cable connectors.

One such limitation is that the contact pierces through the insulation on both sides of the cable. This limitation has several inherent problems. The first problem is that the insulation distance or "spacing" between the conductors has been decreased. A decrease in spacing will reduce the high-voltage carrying capacity of the system and may cause short circuiting failures. The second problem is that piercing through the insulation weakens it, and may cause it to tear and expose an air gap between adjacent conductors, also decreasing the high-voltage carrying capacity of the system. This problem would especially cause concern when using polyimide insulation materials, which have a lower tear resistance than polyester materials.

Another problem emerges when the copper conductor is folded during the engagement of the contact and the conductor. Since copper is a ductile material, it does not provide enough spring resistance and will create an unreliable elec-

trical contact as the copper relaxes over time and reduces the contact pressure at the connection point. Also, if the conductor does not fold, it will be either damaged or broken. Also, its current carrying capacity will be decreased.

A large part of the IDC market for flat conductor cable is the crimped-on to contact style. This connection system uses contacts, which are individually crimped onto the conductors of the FFC/FPC and then may be inserted into a connector housing or soldered directly to a PCB. There are various designs for this type of contact. One of these types pierces through both the insulation and the copper conductor, which damages the conductor and reduces its current carrying capacity. Another design pierces through the insulation between the conductors and wraps around the conductor to provide pressure against small lances that pierce the insulation to make contact with the conductor. FIG. 2 shows this type of crimped-on contact.

As previously described, the piercing of the insulation both reduces the spacing between conductors and weakens the insulation, which may tear. Both of these designs rely on the forming of the crimped contact to provide the spring force necessary to maintain a gas-tight electrical contact. If the crimping process is not performed properly and consistently, the contact system will be unreliable. Also, this type of connection leaves the conductive material of the contact exposed on the outside of the cable with only an air gap to provide electrical insulation between the conductors, limiting the high-voltage carrying capacity of the system.

A fourth problem is that in many of these designs the contacts either intentionally or unintentionally may pierce through both the protective surface plating and copper conductors of the multi-conductor cable. Motion at the connection points may expose this copper to the environment and copper oxides may form which will propagate and eventually contaminate the connection causing a short or open circuit failure.

With all of the above-described designs, the conductor density is severely limited due to the space required to provide a contact that is sufficiently strong to provide the minimum contact force for a gas-tight connection. Many of these designs require a large spacing between the conductors and are not capable of being used in newer system designs, which require much higher density connectors.

Finally, previous IDC designs for multi-conductor cables always provided minimal contact area. The various IDC designs either piercing or bending the conductors used the side of the conductors to establish a contact area. Since the conductors in multi-conductor cables are generally flat, meaning the conductors are wider than they are deep, using the side of the conductor to establish a contact area reduces the prospective size of the contact area. A better IDC design would use the wide portion of the conductors thereby increasing contact area. Increased contact area means increased current flow capacity. Also, the multi-conductor cable density is impaired by the required piercing of insulation between conductors instead of making contact with the conductors on their wider surface.

SUMMARY OF THE INVENTION

This invention results from the realization that an IDC can be made more compact than previously available connectors by using a more narrow contact for each conductor in the multi-conductor cable, can be made more convenient by enabling all conductors contained in the multi-conductor cable to be connected with a single user motion, and can connect to multi-conductor cable without damaging the mechanical or electrical integrity of the cable conductors.

3

It is therefore an object of this invention that all conductors in the multi-conductor cable make contact with the invention in a single user motion.

It is a further object of this invention to provide an IDC that will connect multi-conductor cable without causing excessive mechanical damage to the multi-conductor cable conductors.

It is a further object of this invention to provide an IDC that will connect multi-conductor cable without impairing the conductance of the multi-conductor cable conductors.

It is a further object of this invention to provide an IDC that will connect to multi-conductor cable without requiring complete removal of insulation around the conductors.

It is a further object of this invention to provide an IDC that can connect at any location along the cable.

It is a further object of this invention to provide an IDC that can be used without any special preparation of the cable.

It is a further object of this invention to provide an IDC that preserves the spacing between multi-conductor cable conductors.

It is a further object of this invention to provide an IDC that automatically relieves cable strain.

It is a further object of this invention to provide an IDC that maintains sufficient contact pressure over time for a gas-tight connection after full engagement is achieved

It is a further object of this invention to provide an IDC that contacts the wider surface of the conductors to increase current carrying capacity.

BRIEF DESCRIPTION OF THE DRAWINGS

FIG. 1 shows the cross-section of a traditional insulation displacement connector, available in the prior art, as applied to flat flexible cable.

FIG. 2 shows a crimped-on contact from the prior art.

FIG. 3 shows a cross-section of a basic embodiment of this connector.

FIG. 4 is a three-dimensional image of the connector.

FIG. 5 is another three-dimensional image of connector in FIG. 4 with one end of the connector removed to enable viewing of the connector interior.

FIG. 6 is another cross-sectional image of another embodiment of the electrical connector.

FIG. 7 is three-dimensional image of one embodiment of the base of the electrical connector.

FIG. 8 is an exploded three-dimensional view of one embodiment of the connector.

FIG. 9 is an overhead view of the connector, displaying use of the notches in the actuator.

FIG. 10 is a side view of the connector.

FIG. 11 is a cross-sectional image of another embodiment of this invention, in which the connector is used as a board-to-board connector.

FIG. 12 is another cross-sectional image of the embodiment shown in FIG. 11, in which the connecting board is inserted into the connector.

FIG. 13 is a cross-sectional image of another embodiment of this invention, in which a multiple bump design is used for the force concentrator.

FIG. 14 is a blown-up view of the image in FIG. 13, to amplify the multiple bump design.

FIG. 15 is a cross-sectional view of another embodiment of the invention.

4

FIG. 16 is a cross-sectional view of another embodiment of the invention.

FIG. 17 is a cross-sectional view of the multi-conductor cable.

DETAILED DESCRIPTION OF THE INVENTION

This invention is an electrical connector **10**, shown in FIG. 3, for connecting multi-conductor cable **12**. Multi-conductor cable **12** is cable such as flat flexible cable, printed circuits, and similarly constructed cables wherein the cross-section of the conductor **26** has a width dimension **13** greater than the thickness dimension **14**. The surface of each conductor **26**. The inventive electrical connector **10** has a base **16** for holding multiple contacts **18**. The contacts **18** should be positioned substantially in parallel with each other and are located at least partially within the base **16** of the electrical connector **10**. Each contact **18** has at least one insulation-displacing surface **34**. The insulation-displacing surface **34** is preferably a part of the contact **18** and is oriented to remove insulation **22** from along the width dimension **13** of the conductors **26**, described as a width surface **15**. The final part of the electrical connector **10**, in one of its broadest embodiments, is an actuator **24**, interlockable with the base **16**, for pressing the multi-conductor cable **12** against the multiple contacts **18** and, specifically, for pressing the width surface **15** of each of the conductors **26** against the insulation-displacing surface **34** of the contacts **18**.

By pressing the multi-conductor cable **12** against the contacts **18** and, thereby, insulation-displacing surface **34**, when joining the actuator **24** with the base **16**, the force and friction between the multi-conductor cable **12** and insulation-displacing surface **34** removes the insulation **22** from each of the conductors **26** along the width surface **15**. As the actuator **24** interlocks with the base **16**, the conductors **26** are pressed and held against the contacts **18**, thereby making an electrical connection. A second set of conductors is connected, by any of a multitude of means readily discernable by those skilled in the art and therefore not a part of this invention, to the contacts **18** and, when the base **16** and actuator **24** are joined, the electrical circuit with the multi-conductor cable **12** is completed.

This design is similar to an electrical connector for a single conductor cable, which exists in the prior art. For the single conductor IDC, insulation-displacing surface **34** and contacts **18** run perpendicular to the conductor **26**. The inventive connector **10** claimed herein essentially rotates the conductor **26** ninety degrees with respect to the connector **10**. As a result, the contacts **18** run parallel to the path of the conductors **26**, facilitating multiple conductor connection in a minimal amount of space.

A slight modification in the design can be made by causing the insulation-displacing surface **34** to protrude from at least one of the extensions **28**. This modification creates a cutting edge **20** and alters the dynamic of the contact **18**, although the inventive concept of the invention **10** remains unchanged.

A narrower concept of the invention involves having the shape of each of the contacts **18** represented by two extensions **28** extruding at least partially in the same direction with a trough **30** between them. A crossbar **32** connects the extensions **28**. Then, at least one insulation-displacing surface **34** is located on at least one extension **28**, oriented to remove insulation **22** from the width surface **15** of at least one conductor **26**. The resulting shape of the contact **18** is

similar to that of a tuning fork. A further narrowing of this concept of the invention 10, shown in FIG. 6, involves locating at least one force concentrator 42 on each of the extensions 28. The contacts 18 would be designed such that when the actuator 24 presses the multi-conductor cable 12 into the base 16 and against the force concentrator 42, the extensions 28 will be moved outwardly widening the trough 30 and reducing friction applied by the actuator 24 against the insulation-displacing surfaces 34. The force concentrator 42 lifts the insulation-displacing surface 34 off of the cable 12 to avoid exposing too much of the conductors 26 and also to prevent the insulation-displacing surfaces 34 from rubbing on the conductors 26 at full engagement. The point of full engagement is herein described as the point at which the actuator 24 has been forced into the base 16 to its maximum depth such that the insulation-displacing surfaces 34 on the contacts 18 are in stable electrical contact with the conductors of the cable 12. The force concentrator 42, in one embodiment, contains at least two bumps 50 on at least one of the extensions 28, whereby the first bump 50 to make contact with a conductor 26 wipes remaining adhesive and oxidation from the conductor 26 and the remaining bump(s) 50 are used for maintaining electrical contact with the conductor 26.

The connector 10 further contains a depth-limiting feature to mechanically correct for thicker multi-conductor cable 12 and prevent the insulation-displacing surfaces 34 from cutting too deeply into the multi-conductor cable 12, thereby damaging the conductors 26. The depth-limiting feature is a combination of the force concentrator 42, the lead-in radius at the cable forming guide 54 and the depth limiter 48, which is a level of protrusion of the cutting edge 20 from the extension 28, as shown in FIG. 14.

Another narrower concept of the invention requires cross-section of the barrel 44 of the actuator 24 to be shaped similarly to the trough 30, as shown in FIG. 3, to snugly fit within the trough 30 of the contact 18 and maximize sliding friction pressure of the multi-conductor cable 12 against the insulation-displacing surfaces 34.

Another element, which could be added to the invention, is to make the electrical connector 10 base 16 slotted for connection to a male, pinned electrical connector. Alternatively, with the base 16 slotted, a post 36 could extend from the crossbar 32 of each contact 28, through the slots 38 in the base 16 to connect to a female connector or directly to multi-conductor cable 12.

Another narrower concept of the invention involves having at least one insulating divider 40, shown in FIG. 7, located at least partially between a pair of contacts 18 within the base 16. The insulating dividers 40 can also be used to position the contacts 18 at intervals to match the conductor 26 spacing of the multi-conductor cable 12. One embodiment of the insulating divider 40 is to make the dividers 40 bondable to the contacts 18 to create a laminated contact structure.

There are also a number of embodiment variations for the actuator 24. In one embodiment the actuator 24 is composed of an actuator barrel 44 and an actuator neck 52 wherein the neck 52 is narrower than the barrel 44. This actuator 24 design prevents the insulation-displacing surfaces 34 from removing insulation 22 when the actuator 24 becomes fully engaged because the insulation-displacing surfaces 34 and neck 52 provide insufficient opposing force to cause insulation 22 removal. This relief of pressure against the insulation-displacing surfaces 34 allows all of the pressure to be focused between the width surface 15 of the conductors

26, through the barrel 44, and the force concentrators 42, the intended point of electrical contact for this connector 10, optimizing conductance. Conductance herein is understood to be the inverse of resistance. The narrow neck 52 also provides a location for cut and displaced insulation 22 to accumulate. Directing peeled insulation 22 into this narrow neck 52 area prevents it from interfering with the electrical contact area or pushing back the extension 28.

Another actuator 24 embodiment involves making the actuator 24 slidably interlockable with the base 16. By enabling the actuator 24 to slide, the actuator 24 may be disengaged from the base 16 to allow relocating the connector 10 to a different part of the cable 12 and reengaging the connector 10 to the cable 12 without completely separating the actuator 24 and base 16. A similar embodiment of the actuator 24 allows the actuator 24 to interlock with the base 16 in multiple positions, one of which leaves a sufficient gap between the actuator 24 and base 16 so as to allow the cable 12 to be inserted between the actuator 24 and base 16.

The-actuator 24 may also be designed from a material, which is compressible within the range of force that can be applied by the contacts 18. The affect of this design is to allow the actuator 24 to reduce the level of pressure applied to the cable 12 and contacts 28 when it reaches a level that could damage the conductors 26.

In any of the suggested embodiments, the actuator 24 and trough 30 could also be chamfered or rounded, to make it easier for the cable 12 to be pressed tightly against the contacts 18.

Alternative Embodiments

This patent discloses the design for an improved Insulation Displacement Connector 10 for electrically terminating multi-conductor cable 12, Printed Circuit Boards (PCB) and similar electronic devices. The connector 10 consists of an electrically insulating molded plastic base 16 that houses an array of stamped planar metal contacts 18 placed parallel to one another and separated by electrically insulating dividers 40.

The planar contacts 18 are oriented perpendicular to the length of the connector base 16, which places them parallel to the conductors 26 of a cable 12 inserted into the connector 10. An electrically insulating molded plastic actuator 24 slidably attaches to the base 16 in a raised position to allow the cable 12 to be inserted. The cable 12 is accurately aligned by means of a recessed slot 64 in the base 16 sized to the width of the cable 12, which guides the edges of the cable 12. The cable 12 may be more precisely aligned by accurately punching one or more registration holes 58, shown in FIG. 9, in the space between the conductors 26, which will mate to pins molded on the actuator 24. Visual alignment notches 56 provided along the outside of the actuator 24 provide visual alignment verification for inspection purposes after assembly. Once the cable 12 is inserted into the connector 10, the actuator 24 is forced into the base 16 by means of a parallel action tool such as a small arbor press or vise, although conceivably the shape of the actuator 24 barrel 44 could be altered to reduce the force required to engage the connector 10.

Forcing the actuator 24 into the base 16, wraps the cable 12 around the barrel 44 of the actuator 24, forcing the conductors 26 of the cable 12 to simulate a solid core round wire and relieving cable strain. The insertion of the actuator 24 into the base 16 causes the multi-conductor cable 12 to be forced into the contacts 18. As the contacts 18 are engaged, they pierce through and peel off the insulation 22 of the cable 12 to make an electrical connection. The

actuator **24** locks in place at the full engagement point by means of molded-in snap locks **60** and **62**.

The contacts **18** are Integrated 3 Stage Contacts. The contacts **18** have a cable forming guide **54** and depth limiter **48**, which forces the cable **12** to tightly wrap around the barrel **44** of the actuator and **24** deflects the extensions **28** of the contact **18** to compensate for variations in material thickness so that the cutting edge **20** is correctly positioned to pierce the insulation **22** without damaging the conductors **26** of the cable **12**. The contacts **18** are designed such that they do not penetrate through the protective plating of the conductors **26** to the copper underneath so that copper oxidation growth is not a problem. The contacts also have a cutting edge **20** that both pierces through the insulation **22** and adhesive of the cable **12** and peels them back to expose the conductors **26** without damaging them. Finally, the contacts **18** have a force concentrator **42** that both lifts the cutting edge **20** away from the cable **12** to prevent exposing too much of the conductor **26** and deflects the extension **28** sufficiently to provide the force required to make a gas-tight connection. The contact **18** design can use either a single extension, which would allow for increased density of the system, or a double extension, which would put a cutting edge **20** on either side of the barrel **44** for each conductor **26**. Density of the system is defined by the number of contacts **18** or conductors **26** per inch of the cable **12** width.

The force concentrator **42** can be of a single or multiple bump **50** design. The multiple bump **50** design, shown in FIGS. **13** and **14**, provides added benefits. First, the first bump **50** clears away any remaining adhesive and any plating oxidation on the conductor **26** to allow the additional bumps **50** to make a cleaner contact. Second, the multiple bump **50** design provides redundant connection points for greater reliability and increasing the surface area of the connection points for higher current carrying capacity. Finally, as shown in FIG. **14**, the centering of the bumps **50** on the barrel **44** of the actuator **24** effectively locks it onto the actuator **24** for greater stability of the connection under vibration.

The contacts **18** pierce and peel away the insulation **22** of the multi-conductor cable **12** in such a way that the insulation **22** between the conductors **26** remains. Disruption or removal of this insulation **22** between the conductors **26** would leave only an air gap for electrical resistance between the conductors **26** of the circuit and thus reducing the high-voltage resistance of the system. Leaving the insulation **22** between the conductors **26** also allows the multi-conductor cable **12** to retain more of its tensile strength to prevent conductor **26** breakage during engagement due to the force required to pierce and peel insulation **22**. A partial seal may be created around the connection points by applying heat to the contacts **18**, which will cause the adhesive within the cable **12** to melt and flow around the connection.

The contacts **18** are also designed to be free-floating within the connector base **16** so that they may self-align to the cable **12** and actuator **24** as the system is engaged. This ensures that the contact pressure will be equally distributed at the two connection points made between the contacts **18** and each conductor **26**. Also, the contacts **18** are of a potential energy type that will maintain the minimum contact pressure required for a gas-tight contact over time even with stress relaxation or creep of the materials.

The actuator **24** serves several functions in the connector **10**. It helps simulate the way a traditional round wire IDC works and strain relieves the cable **12**. Strain relief is accomplished by isolating the electrical contact area from the length of cable **12** that extends from the connector **10**

such that any motion or strain applied to the free end of the cable **12** does not affect the stability of the electrical contact between the contacts **18** and the conductors **26** of the cable **12**.

By wrapping the multi-conductor cable **12** around the rounded barrel **44** of the actuator **24**, it is possible to accurately simulate a solid core round wire. In round wire applications, the copper core of the wire is plastically deformed to a more oblong shape when it is inserted into the contact **18**. The deformation increases the amount of contact area between the “U” shaped contact **18** and the copper conductor **26**. It is generally recommended that the contact area be a minimum of twice the cross-sectional area of the copper conductor **26**. In the proposed connector **10** design, both the backing insulation **22** and the plastic actuator **24** can compress slightly to mimic the distortion of a round conductor **26** wire to achieve the needed contact area.

Wrapping the cable **12** around the actuator **24** and engaging it automatically strain relieves the circuit. This will prevent the cable **12** from being able to be pulled out of the connector **10** and prevents vibration or movement of the cable **12** from causing any discontinuity in the electrical connection under vibration conditions. The cable forming guide **54** of each extension **28** can be chamfered to optimize engagement between the cable **12** and the barrel **44** of the actuator **24**, improve positioning of the cable **12** and prevent lifting of the top dielectric. It is understood that chamfering means radiusing, rounding or any other action that reduces angular corners in items such as the cable forming guide **54**.

When the connector **10** is fully engaged, the cable **12** fits closely against the inner profile of the base **16**. This inner profile is made up of electrically insulating “fins” or insulating dividers **40** which separate the contacts. This system effectively isolates each of the contacts **18** and their connection points so that there are no air-gaps, which would cause high voltage arcing failures. Also, the contacts **18** do not violate the spacing between the conductors **26** and do not require any more space than the conductors **26** themselves so that much higher conductor **26** densities can be achieved. This is partly due to the fact that there are no size limitations placed on the contacts **18** other than that of the material thickness.

Even greater conductor **26** densities can be achieved by using a laminated contact **18** structure where an electrically insulating film is laminated between the contacts **18** in place of the insulation dividers **40** of the base **16**. With this technology, conductor **26** pitches smaller than 0.010 inch can be achieved. Pitch is herein defined as the centerline distance between adjacent conductors **26**. Conductor **26** densities can also be increased by using a multiple actuator **24** system and staggering the contacts **18** on the multiple actuators **24**.

The design of this connector **10** allows the cable **12** to pass completely through so that the connector **10** can be placed at any position along the length of the cable **12**. This makes it possible to build a “jumper” cable assembly for interconnecting multiple devices using a single cable. This connector **10** can be designed as a male or female connector without departing from the principles of the invention.

The connector **10** could, alternatively, be built as a board-to-board connector **66**, FIGS. **11** and **12**. In this case, the connector **66** would not need an actuator **24**. The contacts **18** would be constructed to frictionally strip insulation **22** from one circuit board **46** to connect to one or more conductors **26** on that board **46** and would also have a connection to a second board. The one circuit board **46** would be pushed into the contacts **18**, similar to the actuator **24**. In this way, the

connector **66** would be interconnectable with one board **46** and connect to another board. The insulation **22** removed from the board **46** is analogous to the insulation **22** removed from the cable **12** in the original embodiment of the invention. A base **16** would also be required, which would at least partially contain the contacts **18**.

A narrower embodiment of the board-to-board connector **66** would involve constructing the contacts **18** with two extensions **28**, a crossbar **32** connecting the extensions **28** whereby the extensions **28** and crossbar **32** would be used to connect to the first circuit board **46**, and a remaining portion of the contact **18** interconnectable to the second circuit board. Similar to the original connector **10**, the board-to-board connector **66** could be built with contacts **18** containing force concentrators **42** as previously described.

Another embodiment of the invention **10** is an electrical connection apparatus **10** including multiple contacts **18** and a housing **68** to which the contacts **18** are secured and which is removably interlockable and reinterlockable with the multi-conductor cable **12**. While the housing **68** has been described throughout the description as an actuator **24** and a base **16**, the housing **68** is capable of being constructed in other ways. The inventive nature of this design does not require having an actuator **24** or base **16**, but revolves around the reusability of the connector **10** and the frictional removal of insulation **22** to make contact with the conductors **26** in the cable **12**.

The method **80** of making connection used by this invention is also unique. Therefore, it is another embodiment of this invention to make a connection with multi-conductor cable **12** using this disclosed method **80**. The first step is pressing **82** the cable **12** against at least one contact **18**. Then this method **80** requires sliding **84** the cable **12** against the contact **18** at least once and in at least one direction substantially parallel to the length of the cable **12**, such that the frictional force at least partially removes the insulation **22** from the the multiple conductors' width surface **15**. The final step is maintaining **86** contact between the cable **12** and the contact **18**, thereby allowing electrical current to flow between the contact **18** and at least one of the conductors **26**.

This inventive method **80** may further include the steps of aligning **88** the cable **12** with a connector base **16**, inserting **90** an actuator **24** into the base **16** wherein the multi-conductor cable **12** is pressed against the multiple contacts **18** so as to displace the insulation **22** from the multiple conductors **26** on the width surface **15**. An additional step would be interlocking **92** the actuator **24** with the base **16** at the point of full engagement to maintain electrical contact between the conductor **26** on the width surface **15** and the contact **18**.

This inventive method **80** may further include wrapping **94** the multi-conductor cable **12** around the barrel **44** of the actuator **24** and holding it tightly against the barrel **44** with the contacts **18** such that the cable **12** is strain relieved.

This invention may also be provided as a terminated cable assembly **70**. The assembly **70** includes a base **16**, an actuator **24**, and a multi-conductor cable **12** sandwiched between the base **16** and the actuator **24**. The assembly **70** should further include multiple contacts **18** located at least partially within the base **16**, wherein the conductors **26** are held in electrical contact against the contacts **18** by the actuator **24** in an area of the conductors **26** where insulation **22** on the width surface **15** of the conductors **26** has been partially displaced by the contacts **18**.

We claim:

1. An electrical connection apparatus for connecting multi-conductor cable having multiple conductors wherein

each conductor is substantially surrounded by insulation, said multi-conductor cable being cable from the group of flat flexible cable, laminated printed circuits, encapsulated round wire ribbon cable, and cables with multiple conductors, said connection apparatus comprising:

a base;

multiple contacts, located at least partially within the base and having at least one extension, each of said contacts comprising:

at least one depth limiter located on at least one extension; and

at least one insulation-displacing surface located on at least one depth limiter oriented to remove the insulation from a surface of each of the conductors in the cable, wherein the contacts are oriented to electrically contact the surface of the conductors and the depth limiter limits a depth of the insulation removed thereby preventing the insulation-displacing surface from damaging the conductors; and

at least one actuator, interlockable with the base, for engaging the multi-conductor cable with the multiple contacts.

2. The electrical connection apparatus of claim 1 wherein each contact further comprises:

two extensions extruding in at least a partially similar direction;

a crossbar connecting the two extensions; and

at least one insulation-displacing surface, located on at least one extension, oriented to remove the insulation from the width surface of at least one of the conductors, wherein the contacts are oriented to electrically contact the width surface of the conductors.

3. The electrical connection apparatus of claim 1 wherein each of said contacts further comprises at least one bump, at least one of said bump located on at least one of the extensions adjacent to the depth limiter, such that when the actuator is pressed into the base and against the bump, the actuator pressing the cable against the bump, will move the extension in a direction away from the actuator thereby applying electrical contact force between the conductor and the bump.

4. The electrical connection apparatus of claim 3 wherein the force concentrator comprises multiple bumps on at least one of the extensions whereby the first bump to make contact with a conductor wipes remaining adhesive and oxidation from the conductor and remaining bumps are used for maintaining contact with the conductor.

5. The electrical connection apparatus of claim 3 wherein, when the actuator is interlocking with the base, the force concentrator deflects the contact extension when it comes in contact with the conductor and moves the insulation-displacing edge out of the multi-conductor cable insulation, thereby limiting the amount of insulation removed.

6. The electrical connection apparatus of claim 1 wherein a portion of the actuator, which presses the multi-conductor cable against the multiple contacts, substantially conforms in shape to the contacts as positioned in the base.

7. The electrical connection apparatus of claim 1 wherein the base is slotted and the contact includes a female receptacle thereby allowing connection to a male, pinned electrical connector.

8. The electrical connection apparatus of claim 7 wherein the contacts further comprise a post extending through the slots in the base, thereby allowing connection to a female electrical connector.

9. The electrical connection apparatus of claim 1 further comprising at least one insulating divider each located between a pair of contacts.

11

10. The electrical connection apparatus of claim 9 wherein the insulating dividers are a permanent part of the base.

11. The electrical connection apparatus of claim 10 wherein the insulating dividers position the contacts at intervals to match the conductor spacing of the multi-conductor cable.

12. The electrical connection apparatus of claim 9 wherein the insulating dividers are bondable to the contacts to create a laminated contact structure.

13. The electrical connection apparatus of claim 1 wherein the actuator comprises a barrel and a neck and the actuator neck is narrower than the actuator barrel whereby the neck of the actuator provides space for the removed insulation to collect.

14. The electrical connection apparatus of claim 1 wherein the actuator is slidably interlocked with the base.

15. The electrical connection apparatus of claim 1 further comprising visual alignment notches for cable alignment verification after engagement.

16. The electrical connection apparatus of claim 1 wherein at least one of the contacts has a chamfered tip.

17. The electrical connection apparatus of claim 1 wherein the insulation-displacing surface protrudes from the extension thereby forming a cutting edge.

18. The electrical connection apparatus of claim 1 wherein the cable is capable of passing completely through the connector so that the connector is capable of being attached at any point along the length of the cable.

19. The electrical connection apparatus of claim 1 wherein the actuator interlocks with the base in multiple positions, one of which leaves a sufficient gap between the actuator and base, so as to allow the multi-conductor cable to be inserted between the actuator and base.

20. The electrical connection apparatus of claim 13 wherein the actuator barrel is made from a material that is compressible within the range of force that can be applied by the contacts thereby compensating for a thickness of the cable.

21. The electrical connection apparatus of claim 1 wherein an entry side of the base substantially conforms in shape to the actuator and is chamfered to wrap the multi-

12

conductor cable around the actuator when the actuator is engaged with the base.

22. The electrical connection apparatus of claim 2 wherein the actuator further comprises a barrel with a tapered leading edge for allowing the contacts to gradually align to the multi-conductor cable.

23. The electrical connection apparatus of claim 2 wherein the base further restrains the contacts from vertical motion out of the base, thereby allowing the contact to be free-floating in a horizontal direction, which allows the contact to self-align on the actuator and multi-conductor cable.

24. The electrical connection apparatus of claim 13 wherein the actuator further comprises at least one tapered alignment pin in a hole in the multi-conductor cable, located between conductors of the multi-conductor cable, whereby the actuator, as it is engaged into the base, aligns the multi-conductor cable to the multiple contacts.

25. An electrical contact for use in a connector for connecting to multi-conductor cable, said multi-conductor cable having insulation and multiple conductors, each of said conductors having a surface, and said cable being from the group of flat flexible cable, fully laminated and cover-coated flexible printed circuits, encapsulated round wire ribbon cable, ultrasonically laminated adhesiveless flat conductor cables, and other cables with multiple flat conductors, said contact comprising:

- at least one extension;
- at least one insulation-displacing surface located on at least one extension, oriented to pierce through and at least partially remove the insulation and adhesive from the surface of the conductor along a length of the multi-conductor cable;
- at least one chamfered tip at an end of contact extension for wrapping the multi-conductor cable around an activation means;
- a first bump on the extension for wiping adhesive and oxidation from the surface of the conductor; and
- at least one additional bump that makes electrical contact with the conductor.

* * * * *